

## Ventosas cristales



Capacidad  
máxima  
**150 Kg**

Capacidad máxima	150 Kg
Peso	86 Kg
Ventosas	2 uds. x Ø 2,30 m
Largo mínimo	0,61 m
Largo máximo	0,81 m
Altura mínima	0,74 m
Altura máxima	1,74 m
Tipo ventosa	Ventosa manual

NOTA: las dimensiones de algunas unidades de este modelo pueden variar.

## Equipo

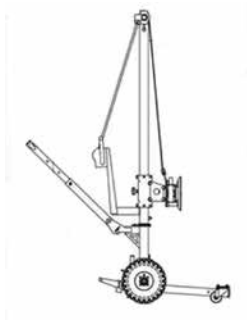
Plataformas  
EléctricasPlataformas  
DiéselManutención  
IndustrialManipuladores  
de cargaPlataformas  
especialesMini-Grúas  
y vidrio

# UPT 150 Racelift 3.0

One-man operation for glass, steel and other smooth material

## UPT 150

Order No.: 106478

- » For lifting, lowering or tilting elements up to 150 kg
- » Uncomplicated and fast setup
- » Total width from 675 mm to 905 mm (without suction unit)
- » Lifting height 1.7 m
- » Rotates elements up to 2.4 m in length
- » Pole swivelable by  $\pm 90^\circ$
- » Suction unit rotatable  $360^\circ$
- » Non-slip handles
- » PU-tires ( $\varnothing 350$  mm)

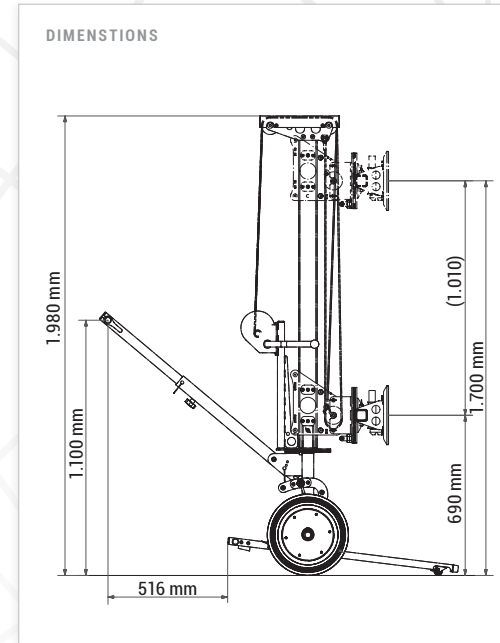

**TECHNICAL DATA**

<b>Bearing capacity</b>	Max. 150 kg
<b>Vacuum cups</b>	2 pieces, $\varnothing 230$ mm
<b>Weight</b>	86 kg
<b>Drive</b>	Manually
<b>Handle</b>	Non-slip support
<b>Tires</b>	PU-tires ( $\varnothing 350$ mm)
<b>Others</b>	Can be disassembled without tools
<b>Optional</b>	Side offset $\pm 65$ mm, suction surface enlargement

